

# MotorGuide® REPAIR PARTS

**Model:**  
**552V**

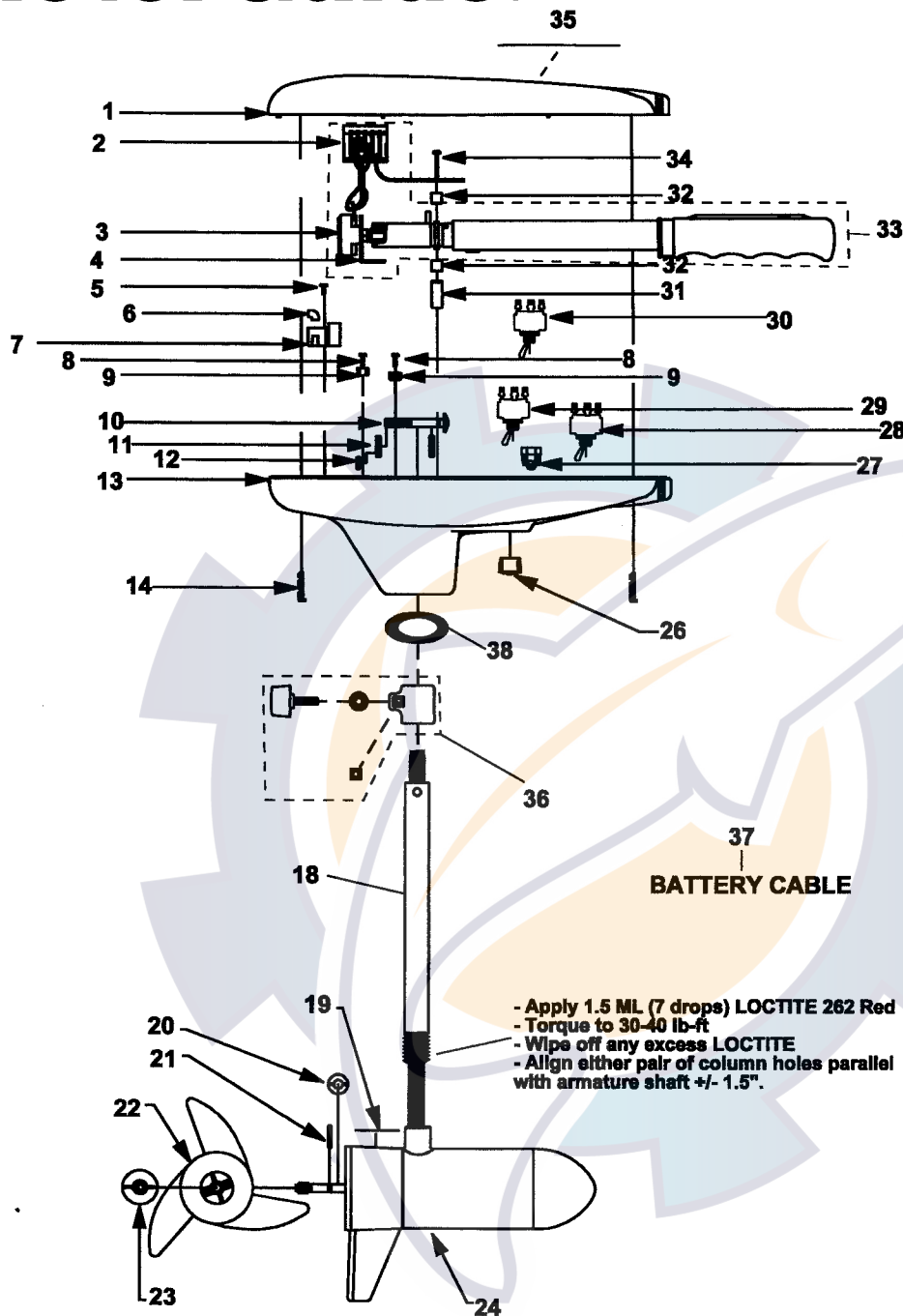

**SPECIFICATIONS:**

Year of Intro	1999
Thrust	52LBS
Volts	12VDC
Amp Draw	0 to 48 amps
Mount	15 Bow
Speeds	Variable

**QUICK REFERENCE PARTS GUIDE:**

FOR/REV Switch	FP153-06
DA Board	JF157-03
MOSFET	JF096-07
Motor Seal Kit	6220

**PARTS ORDERING & TECH ASSISTANCE**

MotorGuide Consumer Relations  
Phone 918-831-6989  
Fax 800-982-8093

*Returned Goods must be accompanied with a Returned Goods Authorization. Contact MotorGuide Consumer Relations to obtain RGA.*

- Apply 1.5 ML (7 drops) LOCTITE 262 Red  
- Torque to 30-40 lb-ft  
- Wipe off any excess LOCTITE  
- Align either pair of column holes parallel with armature shaft +/- 1.5".

KEY	DESCRIPTION	PART #	KEY	DESCRIPTION	PART #
1	TOP HOUSING COVER BLACK	AT053-18	19	LOWER UNIT DECAL	AF060-07
2	TOP HOUSING COVER WHITE	AT053-17	20	MONOFILAMENT WASHER	AR175-01
3	AMP CONNECTOR	AP029-01	21	PROP DRIVE PIN	BR102-01
4	POTENTIOMETER	AP168-02	22	PROP/2 BLADE	AF124-07
5	POT BRACKET	AT155-03	23	PROP NUT	AR099-01
6	SELF TAPPING SCREW	AF141-01	24	H/O MOTOR	CF397-10
7	INSULATING SLEEVE	AT080-01	25	DEPTH ADJUSTMENT COLLAR	AR051-01
8	12 VOLT DURA AMP BOARD	JF157-03	26	HOLE PLUG	FP021-03
9	#10 X 1/2" SCREW	GR133-01	27	GROMMET	GR019-03
10	TERMINAL BLOCK	FT160-01	28	TOGGLE SWITCH 3 POSITIONS	FP153-05
11	BOLT	TT134-01	29	FWD/REV SWITCH 2 POSITIONS	FP153-06
12	CURVED WASHER	TT171-04	30		
13	NYLON LOCK NUT	XT098-02	31	WIRE BRACKET	AT155-04
14	T/H BASE BLACK	AR004-14	32	RETAINER CLAMP	AR036-01
15	T/H BASE WHITE	AR004-13	33	HANDLE ASY	AT372-03
16	SCREW #8 X 1"	LF141-04	34	8 X 1-3/8 SCREW	AR133-01
17	BAR KNOB DEPTH ADJUSTMENT	AR082-02	35	NOMENCLATURE	KT056-11
18	COLUMN CLAMP WASHER	AR171-01	36	DEPTH COLLAR ASY	AR158-01
	COLUMN SUPPORT NUT	FR098-01	37	BATTERY CABLE	BT328-03
	COLUMN 42"	FR049-15	38	COLUMN SEAL	AT079-01

Model:  
**552V**

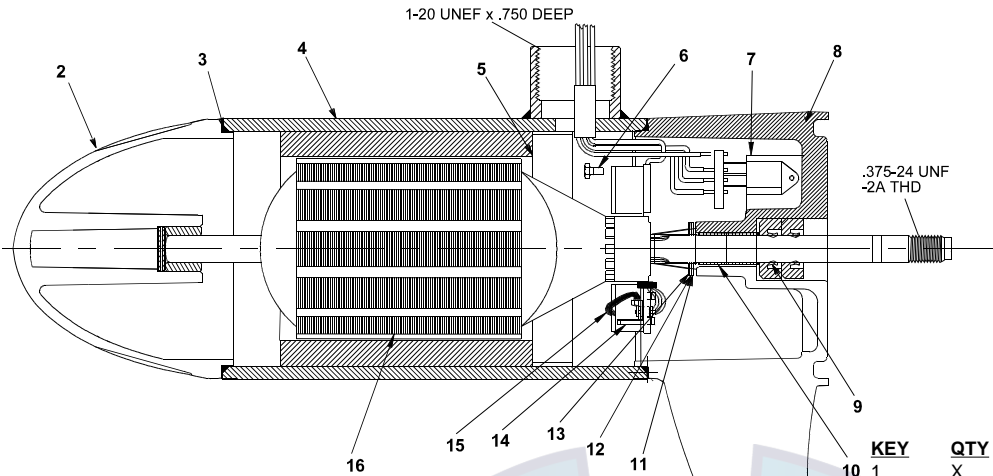

DIRECTION OF ROTATION IS COUNTER CLOCKWISE WHEN VIEWED FROM PROPELLER END WITH RED POSITIVE & BLACK NEGATIVE.

NOTE: TORQUE MOSFET BOLTS TO 35 TO 40 INCH LBS.

NOTE: TORQUE THRU BOLTS TO 40 TO 50 INCH LBS.

KEY	QTY	DESCRIPTION	PART NO.
1	X	MOTOR	CF397-10
2	1	NOSE CAP	XF3212-01
3	2	O RING SEAL	MR217-01
4	1	HOUSING ASY	JF3210-01
5	1	RETAINER	JF233-01
6	2	BRUSH CARD SCREW	MR228-01
7	1	DURA AMP MODULE	JF096-07
8	1	COMM CAP	XF3205-01
9	2	SHAFT SEAL	MR223-01
10	1	BEARING	MR206-01
11	1	NYLATRON WASHER	MR226-01
12	1	WASHER	MR227-01
13	1	E RING	MR219-02
14	2	BRUSH SPRINGS	MR214-02
15	1	BRUSH ASY LESS SPRING	UF3201-05
16	1	ARMATURE	CF3207-01
17	4	STATIC SEAL	MR222-01
18	4	THRU BOLT WASHER	MR216-01
19	2	DURA AMP SCREW	MR229-04
20	2	THRU BOLT	MR218-02

**WIRING**

12V OR 24V D.A. WIRING DIAGRAM

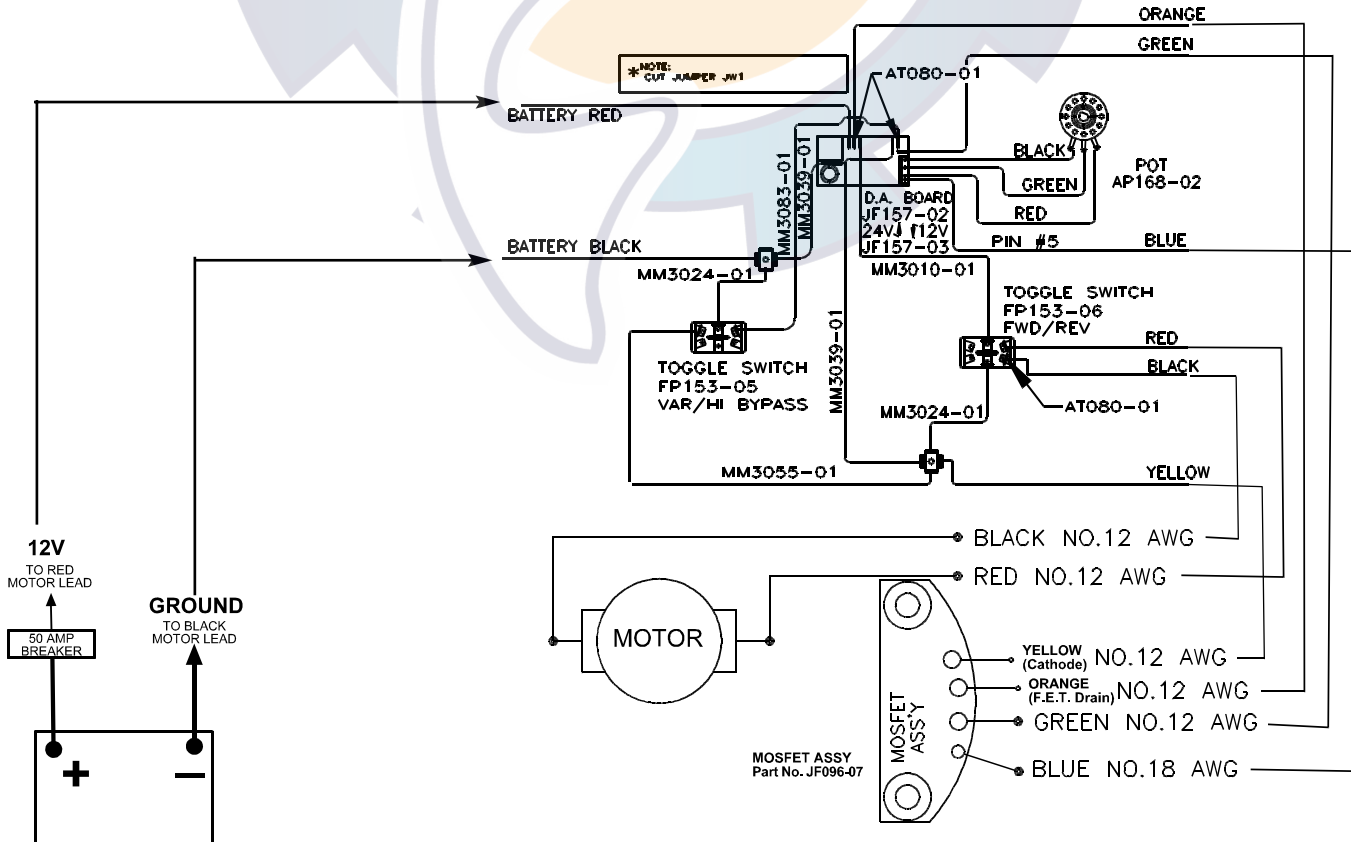

SUBJECT TO DAMAGE BY STATIC ELECTRICITY ASSEMBLE AT STATIC FREE WORK STATION!